



SUNERGY

SUNERGY USA WORKS LLC

www.sunergyworks.com

# SUN 72M

350W/355W/360W/  
365W/370W

MONO CRYSTALLINE MODULE

IEC61215 / IEC61730

exquisite  
workmanship  
and excellent quality.



### IP68 Junction Box, Connector

IP68 Junction Box and Connector have a high degree of waterproof, effectively resist the harsh environment



### 15A current

The junction box carries a current of 15A, ensuring high current flow through the modules



### Super strong frame

Glue-spilled tank has a double-layer waterproof, cross-section with hook-shaped aluminum frame, enhanced by 10% of the mechanical load strength



### Current division

The module refines the current division, thus effectively reducing the loss of up to 2% due to mismatch and increasing the power output of the system



### Strong Mechanical load capacity

Passed the 2400pa wind load and 3600pa snow load test, ensuring that the module has a stable mechanical life



### Color Classification

Modules are packaged according to color classification, to achieve

### LINEAR PERFORMANCE WARRANTY

- 10 Years Manufacturing Warranty
- 12 Years 90% Power Output
- 25 Years 80% Power Output

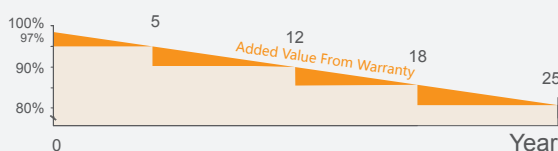

Module Manufacturer : Chinaland Solar Energy Co., Ltd.

Address: Feidong New City Economic Development Zone,  
Hefei, 231600, Anhui Province, PR China

Tel/Fax: +86 551 67758555

Web: www.chnland.com

E-mail: chnland@chnland.com



MECHANICAL DRAWINGS

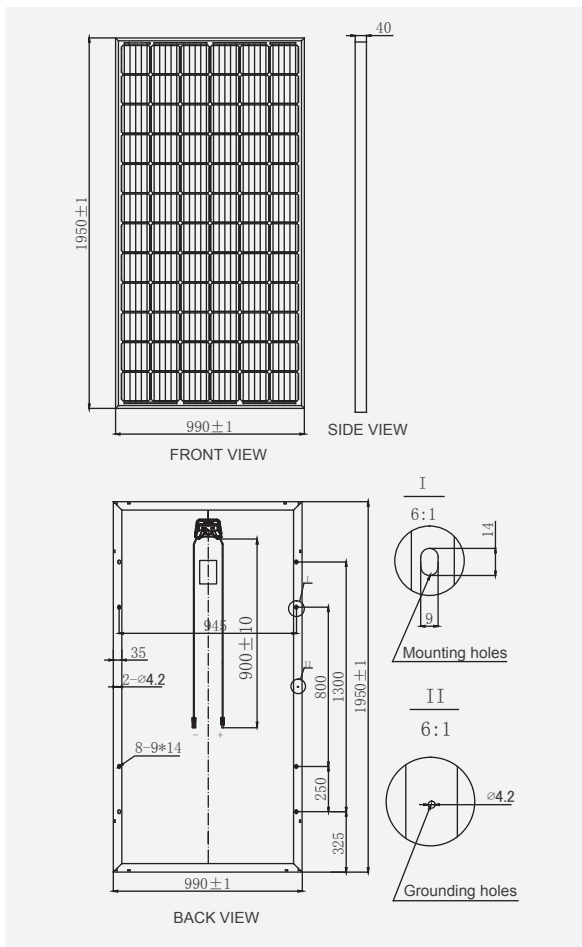

MECHANICAL SPECIFICATION

Cell Type	Mono Crystalline 156.75x156.75mm
Number Of Cells	72 (6x12)
Dimensions(AxBxC)	1950x990x40mm
Weights	23kg
Front Glass	3.2mm Tempered Low Iron Glass
Frame	Clear Anodized Aluminum Alloy
Junction Box	IP68,with Bypass Diodes
Connector	PV-CL001
Output Cables	Tuv,±length 900mm,4.0mm <sup>2</sup>

ELECTRICAL CHARACTERISTICS

Module NO.	SUN350-72M	SUN355-72M	SUN360-72M	SUN365-72M	SUN370-72M
Maximum Power At STC(Pmax)	350W	355W	360W	365W	370W
Short Circuit Current(Isc)	9.53A	9.65A	9.75A	9.82A	9.85A
Open Circuit Voltage(Voc)	47.5V	47.7V	47.9V	48.1V	48.3V
Maximum Power Current(Imp)	9.04A	9.15A	9.25A	9.34A	9.41A
Maximum Power Voltage(Vmpp)	38.7V	38.8V	38.9V	39.1V	39.3V
Module Efficiency	18.13%	18.39%	18.65%	18.91%	19.17%
Power Tolerance	±5%	±5%	±5%	±5%	±5%

STC: 1000W/m<sup>2</sup> irradiance, 25°C cell temperature, AM1.5.

NOCT

Maximum Power At STC(Pmax)	260.9	264.6	268.3	272.1	275.8
Short Circuit Current(Isc)	7.72	7.81	7.89	7.95	7.97
Open Circuit Voltage(Voc)	43.9	44.1	44.3	44.5	44.7
Maximum Power Current(Imp)	7.31	7.41	7.48	7.54	7.56
Maximum Power Voltage(Vmpp)	35.7	35.7	35.9	36.1	36.5

NOCT: Irradiance at 800W/m<sup>2</sup>, Ambient Temperature 20°C, wind speed 1m/s.

I-V CURVES

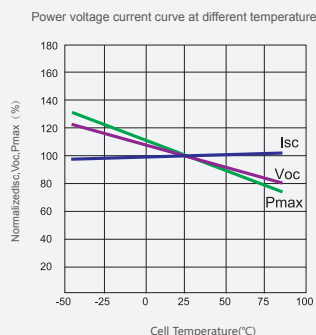
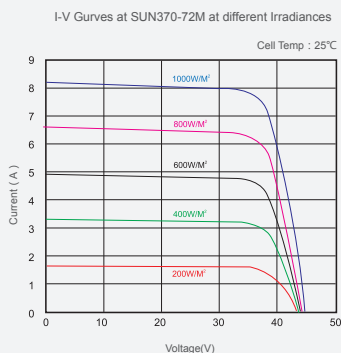

SYSTEM INTEGRATION PARAMETERS

Maximum System Voltage	VDC 1000V
Maximum Series Fuse	15A
Increased Snowload Acc.to Iec 61215	3600Pa
Operating Temperature	-40~+85°C
Number Of Bypass Diodes	3

TEMPERATURE CHARACTERISTICS

Norminal Operating Cell Temperature(Noct)	45°C±2°C
Temperature Coefficient Of Pmax	-0.40%/°C
Temperature Coefficient Of Voc	-0.29%/°C
Temperature Coefficient Of Isc	0.05%/°C

PACKING CONFIGURATION

	20' GP	40' GP
Container		
Pieces Per Pallet	27	27
Pallets Per Container	10	24
Pieces Per Container	270	648